

CAD FILE:

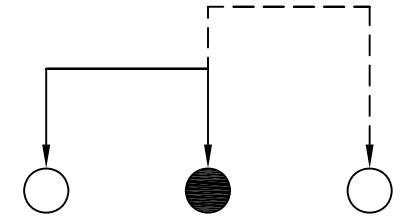

SCHEMATIC (NON-SHORTING)

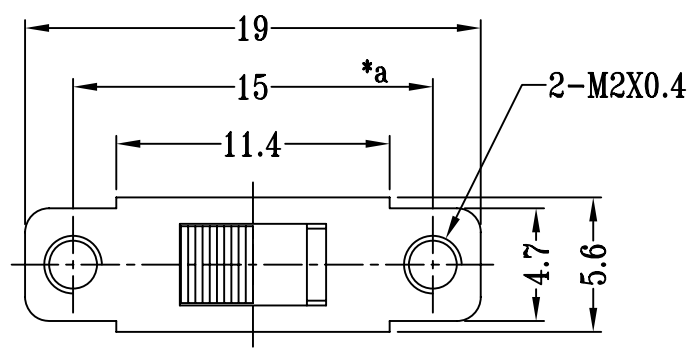
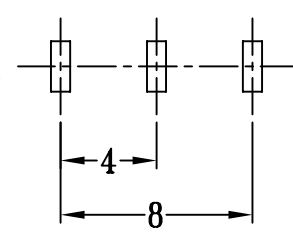
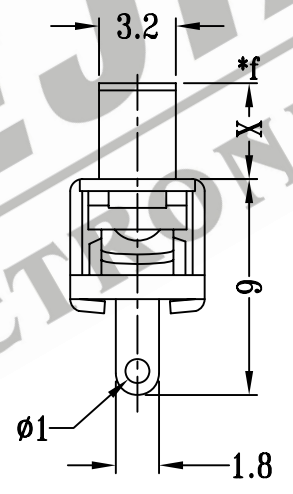
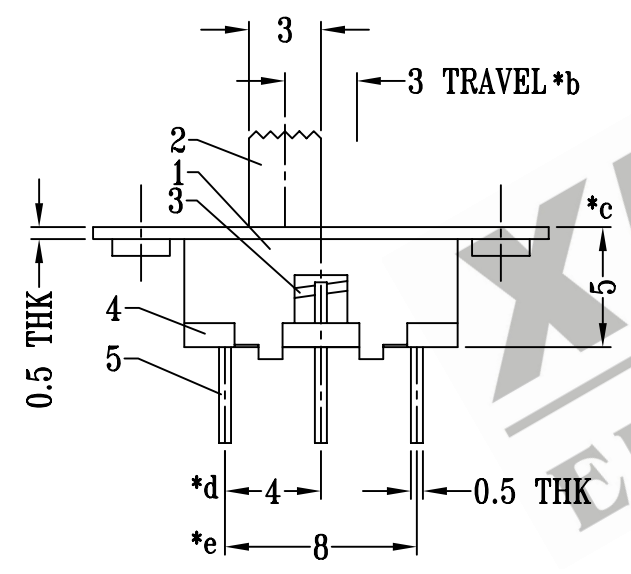

P.C.B LAYOUT

注:带"\*"表示关键尺寸(6个)

NO.	PARTS	MATERIALS	Q'TY	FINISH	TOLERANCE UNLESS SPECIFIED	SHENZHEN XIEJIA ELECTRONICS CO.,LTD.				
8						TITLE : VERTICAL SLIDE SWITCH				
7	SPRING	STEEL WIRE	1	TEMPER						UNIT : mm
6	STEEL BALL	STEEL	1	NATURAL	WITHIN: 1.5±0.1mm	SCALE: 3 : 1		DWN.	ZHOUYU	2003-8-17
5	TERMINAL	BRASS STRIP	3	Ag PLATED OVER Ni PLATED	OVER : 1.5±0.2mm			CHK'D	FANGYING	2003-8-17
4	BASE	PHENOLIC RESIN	1	NATURAL			ISSUE		DATE	DESCRIPTIONS OF REVISION
3	CONTACT CLIP	BRASS STRIP	1	Ag PLATED			APPD.		KANGXINAN	2003-8-17
2	KNOB	POM	1	BLACK						
1	FRAME	STEEL STRIP	1	BLACK						
ALL MATERIALS MUST BE COMPLIANT TO ROHS										